

ULTRASONIC FLOWMETER (2-Path System type)

DATA SHEET

FSH, FSS, FLY

This flowmeter is a fixed type ultrasonic flowmeter based on transit-time measuring method.

The flowmeter is a compact and light-weight instrument incorporating the latest electronics and high speed digital signal processing technologies, realizing high performance and easy operation. This high performance flowmeter is used for 2-path system only.

FEATURES

1. Compact and light-weight

Thanks to the adoption of the latest electronics the flow transmitter size and mass are 1/2 of our traditional instrument.

2. Full variety of sensors

The flowmeter can be used with various types of sensors applicable for wide range of pipe size ($\phi 13$ to $\phi 6000$ mm) and fluid temperature (-40 to $+200^{\circ}\text{C}$).

3. High accuracy

The flowmeter is designed for high accuracy ($\pm 1.0\%$). The adoption of new sound velocity measurement system permits measurements of fluids of unknown sound velocity, and also slightly affection from fluid temperature and pressure.

4. Excellent resistance against aerated flow

Fuji's unique ABM feature improves measurement reliability for different flow like slurries, sludge, raw sewage and bubble-contained flow (acceptable up to air bubble of 12% volume at 1m/s velocity).

5. Quick response

With the use of high-speed micro-processor suited for digital signal processing, the fast response time is realized.

6. Multi-lingual

The following languages are supported for display: Japanese (Katakana), English, German French, and Spanish.

7. Excellent performance and easy operation

LCD and function keys are allowing easy configuration and trouble shooting.

- LCD with back light
- Easy mounting of sensor
- Extendable rail type detector up to $\phi 50$ to $\phi 1200$ mm
- Trouble shooting

SPECIFICATIONS

Operational specifications

System configuration:

The system is composed of two detectors (Model: FSS) and one Flow transmitter (Model: FSH), realizing two-path measurement.

Applicable fluid: Homogenous liquid where the ultrasonic signal can be transmitted

Bubble quantity: 0 to 12vol% (for pipe size 50A, water, velocity 1m/s)



Flow transmitter (FSH)

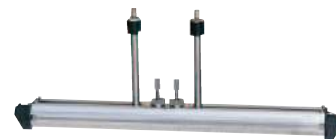

Detector (FSSH)



Detector (FSSE)



Extendable rail type detector (FSSC)

Fluid turbidity: 10000mg/L max.

Type of flow: Fully-developed turbulent or laminar flow in a full-filled pipe

Applicable flow pipe:

Detector Type	Pipe size (inner diameter) mm	Applicable pipe material	How to mount and judge the pipe diameter	Fluid temperature range ($^{\circ}\text{C}$)
FSSC	$\phi 50$ to $\phi 1200$	Plastic (PVC, etc.) (Note 1) Metal pipe (SS, steel pipe, copper pipe, aluminum pipe, etc.) (Note 2)	V method $\phi 50$ to $\phi 600$ Z method $\phi 600$ to $\phi 1200$	-40 to $+120$ (Note3)
FSSH	$\phi 50$ to $\phi 400$		V method $\phi 50$ to $\phi 250$ Z method $\phi 150$ to $\phi 400$	-40 to $+200$
FSSE	$\phi 200$ to $\phi 6000$		V or Z method	-40 to $+80$

Note1) Please select the FSSC type if following condition.

- When pipe material is PP or PVDF, limit of pipe wall thickness is 15mm or more for PP, 9mm or more for PVDF
- When pipe material is hard to penetrate the ultrasonic wave such as cast-iron pipe, lining pipe and old carbon steel pipe etc.,
- Lining material is tar epoxy, mortar and rubber etc..
- In case lining is removed from the pipe, Measurement can not be conducted

Note2) When silicon grease is used as acoustic coupler, Fluid temperature limit is 0 to 60°C no matter what detector is selected.

- Signal cable:** High-frequency coaxial cable and 3-wire shielded cable.
Maximum cable length: 150m
Allowable temperature limit: 80°C
Coaxial cable (4 pcs)
- Environment:** Non-explosive environment without direct sunlight, corrosive gas and heat radiation
- Ambient temperature:**
-10 to +50°C for flow transmitter,
-20 to +80°C for detector
- Ambient humidity:**
95%RH or less for flow transmitter, 100%RH or less for detector
- Grounding:** Class D (less than 100 ohm)
- Arrester:** Surge absorbers for outputs and power supply incorporated as standard

Performance specifications

Accuracy :

Detector	Pipe size (diameter)	Applicable pipe material	Flow velocity	Accuracy
Common type FSGS32 FSD32 FSGS51	ø50 to below ø300	Plastic, metal pipe	2 to 32m/s	±1.0% of rate
			0 to 2m/s	±0.02m/s
	ø300 to ø6000 mm		0.75 to 32m/s	±1.0% of rate
0 to 0.75m/s			±0.0075m/s	
FSGS31 FSGS50	ø50 to below ø300		2 to 32m/s	±1.5% of rate
			0 to 2m/s	±0.03m/s
	ø300 to ø6000 mm	0.75 to 32m/s	±1.5% of rate	
0 to 0.75m/s		±0.0113m/s		

Response time:

Transit time method: 0.5sec

Power consumption:

20W or less

Functional specifications

- Analog output:** 4 to 20 mAdc (1 point)
Max. load resistance: 1k ohm
- Digital output:** +total, -total, alarm, acting range, flow switch or total switch – arbitrarily selectable
- Mechanical relay contact:**
1 point with socket (replaceable)
Normally closed/open selectable
Capacity: 240 Vac/30 Vdc, 1 A
Total pulse: less than 1 p/s
(Pulse width: 50, 100 or 200 ms selectable)
- Transistor open collector:** 2 points
Capacity: 30 Vdc, 0.1 A
Normally off/on selectable
Total pulse: less than 1000 p/s
(Pulse width: 0.5, 1, 2, 5, 10, 20, 50, 100 or 200 ms selectable)
- Communication interface:**
RS-232C equivalent / RS-485 (selectable)
Number of connectable units: one (RS-232C)/ up to 31 (RS-485)
Baud rate: 9600/19200/38400 bps selectable
Parity: none/odd/even selectable
Stop bit: 1 or 2 bits selectable
Distance: up to 15 m (RS-232C)/up to 1k m (RS-485)
Data: velocity, flow rate, +total, -total, status (standard), velocity profile (option)

Display device:

Graphic LCD (number of pixels: 240x64) with back light

Display language:

Japanese, English, French, German or Spanish selectable

Velocity/Flow rate display:

Display of velocity and/or flow rate with flow direction

Data: up to 10 digits (decimal point to be counted as 1 digit)

Unit: Metric/English system selectable

	Metric system	English system
Velocity	m/s	ft/s
Flow rate	L/s, L/min, L/h, L/d, kL/h, ML/d, m ³ /s, m ³ /min, m ³ /h, m ³ /d, km ³ /d, Mm ³ /d, BBL/s, BBL/min, BBL/h, kBBL/d, MBBL/d	ft ³ /s, ft ³ /min, ft ³ /h, Mft ³ /d, gal/s, gal/min, gal/h, Mgal/d, BBL/s, BBL/min, BBL/h, BBL/d, kBBL/d, MBBL/d

Note: "gal" means US gal.

Total display: Display of forward or reverse total

Data: up to 10 digits (decimal point to be counted as 1 digit)

Unit: Metric/English system selectable

	Metric system	English system
Total	mL, L, m ³ , km ³ , Mm ³ , mBBL, BBL, kBBL	ft ³ , kft ³ , Mft ³ , gal, kgal, mBBL, BBL, kBBL, ACRf

Configuration:

Fully configurable on keyboard by menu-driven software

Zero adjustment:

Set zero/Clear available.

Damping: 0 to 100s (every 0.1s) configurable for analog output and display

Low flow cut off:

0 to 5 m/s configurable

Alarm: Hardware fault/process fault can be tied to digital output

Burnout: Analog output: Hold/Upper limit/Lower limit/Zero/Not-used selectable

Total: Hold/Count selectable

Timer: 0 to 900s (every 1s) configurable

Bi-directional range:

Forward and reverse ranges configurable independently

Hysteresis: 0 to 20% of working range configurable

Working range applicable to digital output

Auto-2 ranges:

Forward 2 ranges configurable independently

Hysteresis: 0 to 20% of working range configurable

Working range applicable to digital output

Flow switch: Lower and upper switching points configurable independently

Acting point applicable to digital output

Total switch: +total switching point configurable

Acting point applicable to digital output

Physical specifications

Enclosure protection:

Flow Transmitter: IP67,
 Detector:
 FSG (common type):
 IP67 (Silicon compound is filled on the terminal part when wiring)
 FSG (submersible type):
 IP68 (submersible in water for 5 days)
 FSD (high temperature type): IP52

Mounting: Flow Transmitter: wall mount
 Detector: clamped on pipe surface

Acoustic coupler: Silicon compound (RTV)

Material: Flow Transmitter: aluminum alloy
 Detector:

Detector	Sensor housing	Sensor cover	Guide rail
FSGS3	PBT	SUS304	SUS304 + plastic
FSGS5	PBT	SUS304	-
FSD32	SUS304	-	SUS304 + aluminum alloy

Signal cable: FLY8, FLY9 (applicable detector: FSG, FSD)

- Structure: High frequency coaxial cable (double shield)
- Sheath: Black flame-resisting PVC
- Outer diameter: $\varnothing 7.5\text{mm}$
- Termination: M3.5 amp terminal (flow transmitter side) and M4 amp terminal (FLY8). Note, however, that the detector side of FSD32 is provided with BNC connector (FLY9).
- Mass: Approx. 90g/m

Dimensions: Flow transmitter FSH:
 $H240 \times W247 \times D134\text{mm}$
 Detector: $H46 \times W410 \times D50\text{mm}$ (FSGS3)
 $H67 \times W78 \times D84\text{mm}$ (FSGS5)
 $H205 \times W530 \times D52\text{mm}$ (FSD32)

Mass: Flow transmitter : 5kg
 Detector: 0.6kg (FSGS3)
 1.2kg (FSGS5)
 1.6kg (FSD32)

Conditions on straight pipe

(D : Inside diameter of pipe)

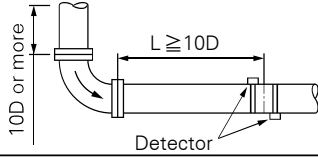
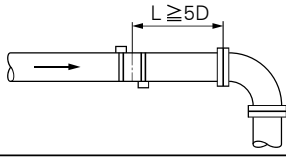
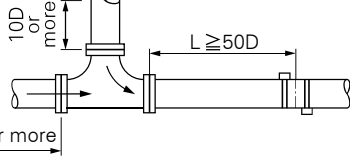
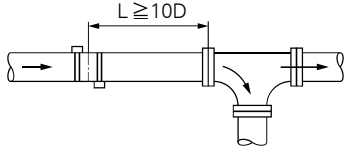
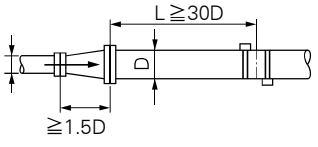
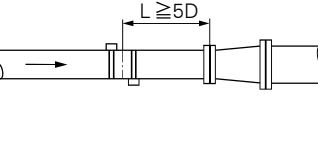
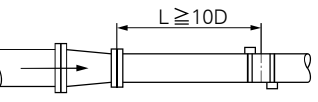
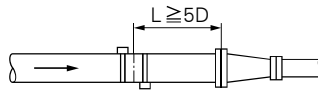
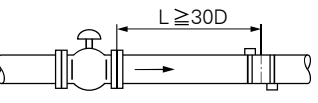
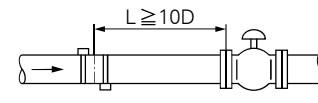
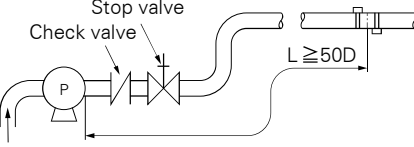
Classification	Upstream side	Downstream side
90 bend		
Tee		
Diffuser		
Reducer		
Various Valve	 In case that flow control valve exists on upstream side.	 In case that flow control valve exists on downstream side.
Pump		

(Note) The source : JEMIS-032

CODE SYMBOLS

<Flow transmitter>

1	2	3	4	5	6	7	8	9	10	11	12	Description
F	S	H	Y	A	1	-	S	Y	Y			
			E									Type (4th digit) Standard
				A								Use (6th digit) Transit time measurement (two path)
					1							Power supply (7th digit) 100 to 240 Vac, 50/60 Hz
					4							20 to 30 Vdc
							Y					Conduit connection (10th digit) G1/2 and G3/8 (female screw) with water-proof connection
								Y				Parameter setting, Tag Plate (12th digit) None A With setting B With setting and Tag Plate C With Tag Plate

<Detector, high temperature type>

1	2	3	4	5	6	7	8	Description
F	S	D					1	
			3	2	0			Type (4th, 5th and 6th digits) High-temperature sensor *1 (ø50 to ø400), V or Z method
						Y		Belt, acoustic coupler (7th digit) *3 For fixed type

<Detector, common type>

1	2	3	4	5	6	7	8	9	10	11	12	13	Description
F	S	G	S			Y	1	-	Y				
													Type (5th and 6th digits) 3 2 Small sensor 2MHz (ø50 to ø300) } V method 3 1 Small sensor 1MHz (ø50 to ø300)*2 } 5 1 Large sensor 1MHz (ø200 to ø6000) } V or Z 5 0 Large sensor 0.5KHz (ø200 to ø6000)*2 } method
									Y				Acoustic coupler (10th digit) None*4
									A				Silicon rubber (KE348W)
									B				Silicone-free grease (HIGH-Z) *5
									C				Silicone grease (G40M)*5
										Y			Additional specification (11th digit) None
									A				Tag plate
											Y		Wire rope for mounting (12th digit) Specify it in the case of FSGS41 or FSGS5.
											A		Nominal diameter: up to ø500mm
											B		Nominal diameter: up to ø1000mm
											C		Nominal diameter: up to ø1500mm
											D		Nominal diameter: up to ø3000mm } Can be specified
											E		Nominal diameter: up to ø6000mm } only for FSGS5

<Detector, submersible type>

1	2	3	4	5	6	7	8	9	10	11	12	13	Description
F	S	G	S			A	1	-					
													Type (5th and 6th digits) 3 2 Small sensor 2MHz (ø50 to ø300) } V method 3 1 Small sensor 1MHz (ø50 to ø300)*2 } 5 1 Large sensor 1MHz (ø200 to ø6000) } V or Z 5 0 Large sensor 0.5KHz (ø200 to ø6000)*2 } method
									B				Dedicated signal cable (9th digit) 10m C 20m D 30m E 40m F 50m G 60m H 70m J 80m K 90m L 100m M 110m N 120m P 130m O 140m R 150m Z Specified length (Contact us if length is more than 150m. Max. length is 300m.)
									A				Acoustic coupler (10th digit) Silicon rubber (KE348) C Silicone grease (G40M) *5
										Y			Additional specification (11th digit) None A Tag plate
												Y	Wire rope for mounting (12th digit) Specify it in the case of FSGS41 or FSGS5.
												A	Nominal diameter: up to ø500mm
												B	Nominal diameter: up to ø1000mm
												C	Nominal diameter: up to ø1500mm
												D	Nominal diameter: up to ø3000mm } Can be specified
												E	Nominal diameter: up to ø6000mm } only for FSGS5

- *1: For turbid fluid or old pipe, cast iron pipe, mortar lining pipe or others through which the ultrasonic signal could not be transmitted easily, use an optional guide rail (TK4C6164C1), and carry out mounting by Z method.
Applicable diameter range
V method: ø50 to ø250 Z method: ø150 to ø400
- *2: For aging pipes, cast iron pipes or mortar-lined pipes that interrupts the propagation of ultrasonic signals, select FSGS31 or FSGS50.
- *3: As for the acoustic coupler, grease (KS62M) for high temperatures is attached.
- *4: Silicone rubber (KE-348W) is provided as a standard accessory to fill the wiring mold. (It can also be used as an acoustic coupler.)
If an additional acoustic coupler is required, select one among A, B and C.
- *5: Normally select silicone rubber as acoustic coupler. Siliconerubber in tube (100g) is furnished. If you place an order for several units, 1 tube may suffice for every 2 units. Select silicone-free grease for semiconductor manufacturing equipment or the like that is vulnerable to silicone. The silicone-free grease is water-soluble and, therefore, cannot be used in environment exposed to water or on piping subjected to a condensation. Since the grease does not set, a periodic maintenance (cleaning, refilling every about 6 months at normal temperature) is necessary.

<Signal cable>

Note: Must be procured unless the sensor is a submersible type.

• For detector FSG and FSD

1 2 3 4 5 6 7 8								Description
F	L	Y					1	Type of sensor (4th digit)
							8	Small and large sensor (for FSG)
							9	Hight temp sensor (for FSD)
								Cable length (5,6 and 7th digit)
			0	0	5			5 m
			0	1	0			10 m
			0	1	5			15 m
			0	2	0			20 m
			0	2	5			25 m
			0	3	0			30 m
			0	3	5			35 m
			0	4	0			40 m
			0	4	5			45 m
			0	5	0			50 m
			0	5	5			55 m
			0	6	0			60 m
			0	6	5			65 m
			0	7	0			70 m
			0	7	5			75 m
			0	8	0			80 m
			0	8	5			85 m
			0	9	0			90 m
			0	9	5			95 m
			1	0	0			100 m
			1	1	0			110 m
			1	2	0			120 m
			1	3	0			130 m
			1	4	0			140 m
			1	5	0			150 m
			Z	Z	Z			Others (contact us)

Note: Prepare a detector and dedicated signal cable (2 set).

Loader software for PCs

Equipped as standard

- Works on PC/AT compatible machines.
- Operation on PC98-series machines (NEC) cannot be guaranteed.
- Operation on self-made PCs or shop-brand PCs cannot be guaranteed.
- Major functions: Setting/changing of various parameters for the main unit
- O/S: Windows 2000/XP or Windows 7 (Home Premium, Professional)
- Memory requirement: 128MB or more
- Disk unit: Windows 2000/XP or Windows 7 (Home Premium, Professional) compatible CD-ROM drive
- Hard disk drive capacity: Free space of 52MB or more

Note: PC loader communication cable (type ZZP*TK4H6253, Specifications: D-sub 9 pin receptacle, cable length 3m) is separately required.

SCOPE OF DELIVERY

- Flow transmitter (Type: FSH): Flow transmitter
CD-ROM (Instruction manual, Loader software)
- Detector (Type: FSG, FSD): Sensor unit, Mounting belt, Silicon compound
- Signal cable (Type: FLY): Cable (2 wires)

ITEMS DESIGNATED ORDERING

1. Detector code symbols
2. Flow transmitter code symbols
3. Signal cable code symbols
4. For large sensor: Mounting pipe size
5. Tag No. as necessary
6. If parameter setting is specified, send back the attached parameter specification table duly filled.

OUTLINE DIAGRAM (Unit:mm)

<Flow transmitter (type: FSH)>

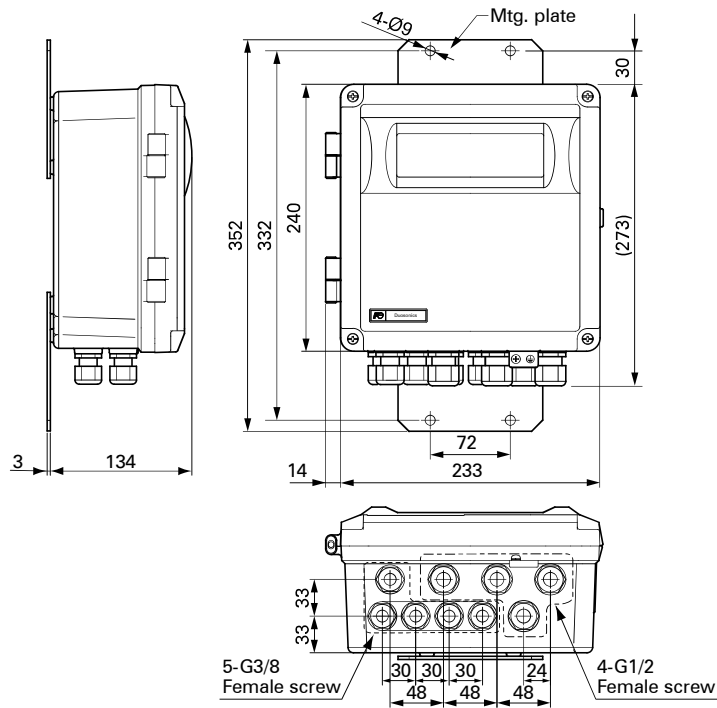

CONNECTION DIAGRAM

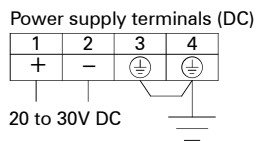
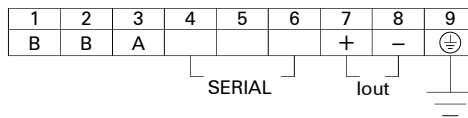
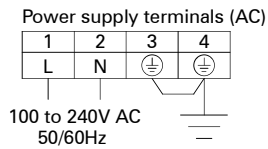

SERIAL

No.	RS485	RS232C	Communication cable (option)
4	TRX2 (-)	TXD	Cap (red)
5	TRX1 (+)	RXD	Cap (yellow)
6	SHILD	COM	Cap (black)

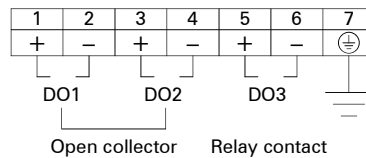
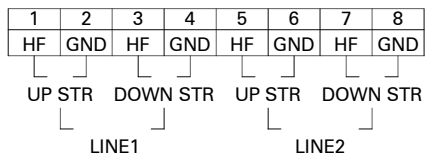

OUTLINE DIAGRAM (Unit:mm)

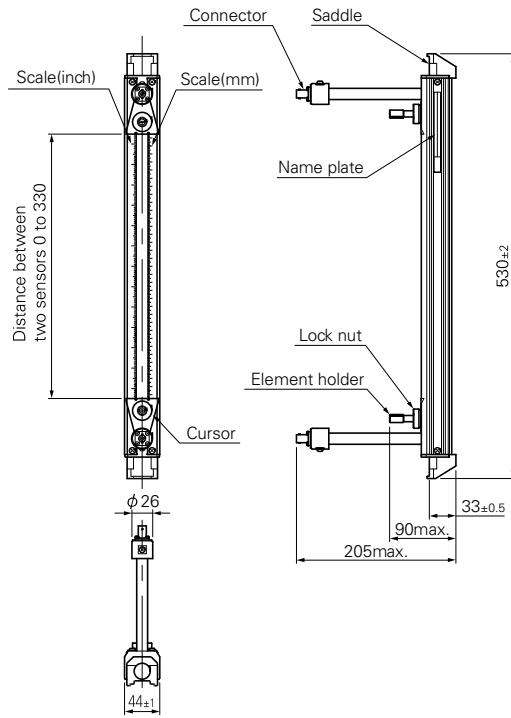

Detector FSD32 (High-temperature sensor)

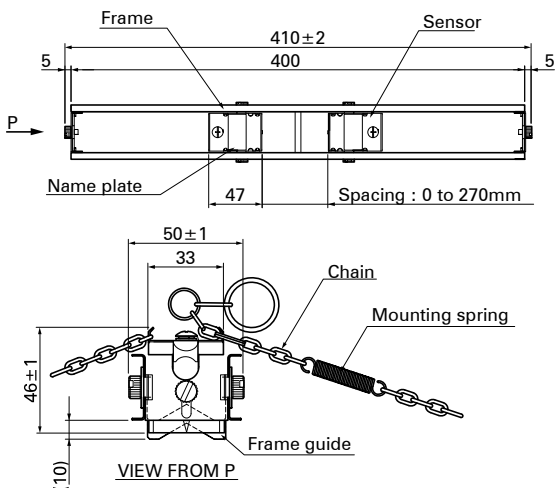

(Common type)

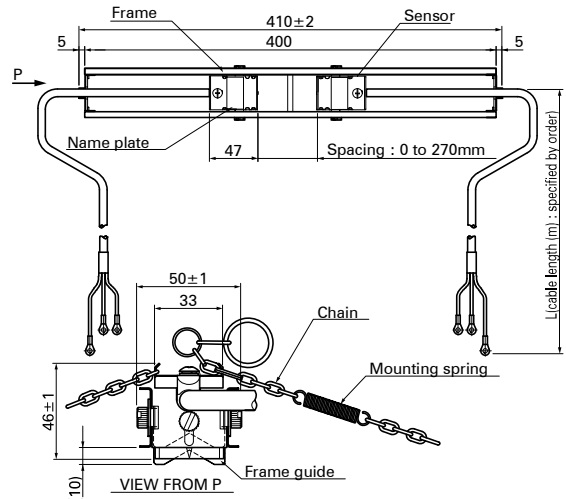

(Submersible type)

Detector FSGS3 (Small sensor)

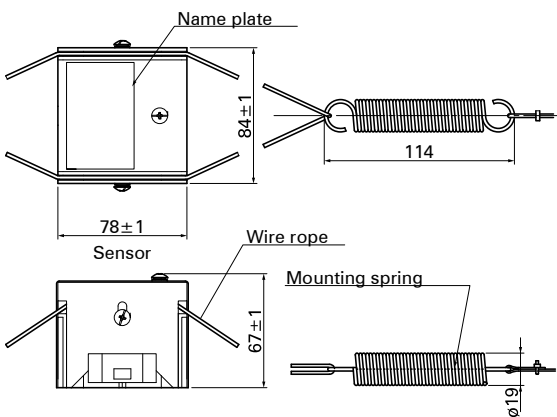

(Common type)

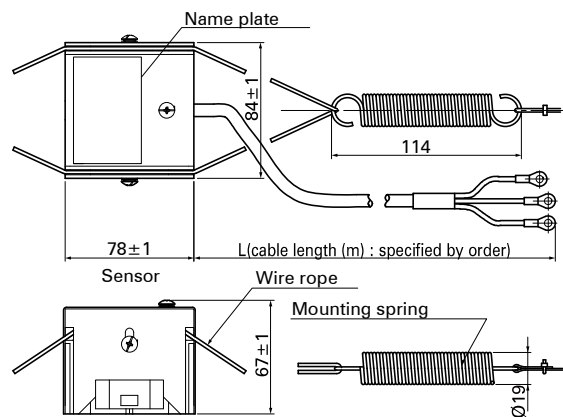

(Submersible type)

Detector FSGS5 (Large sensor)

Signal cable : FLY8 (For FSG)

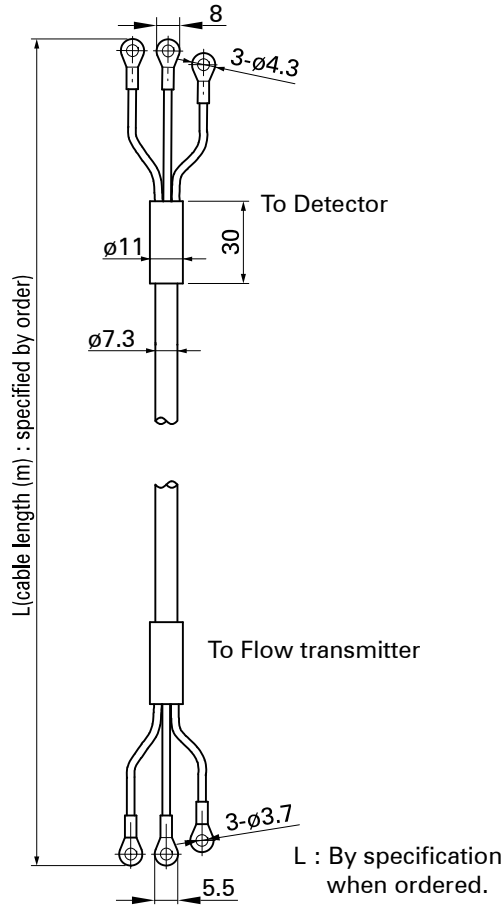

Signal cable : FLY9 (For FSD)

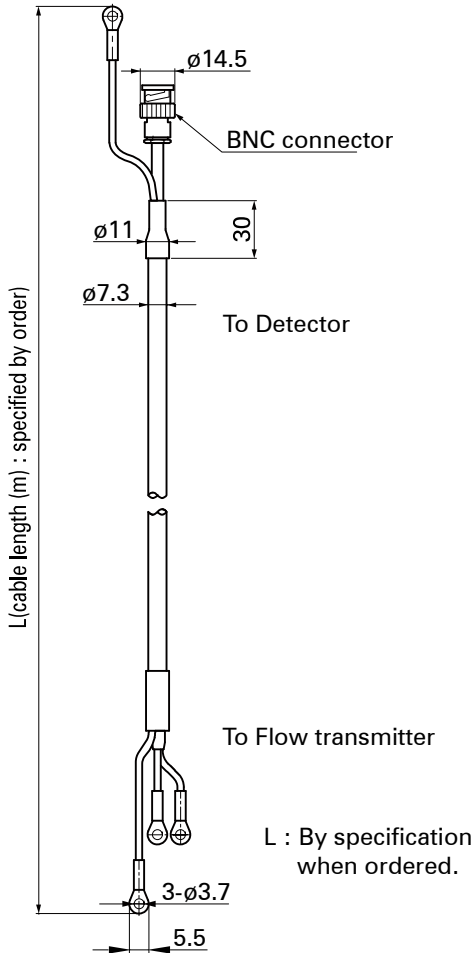

Loader cable : ZZP*TK4H6253

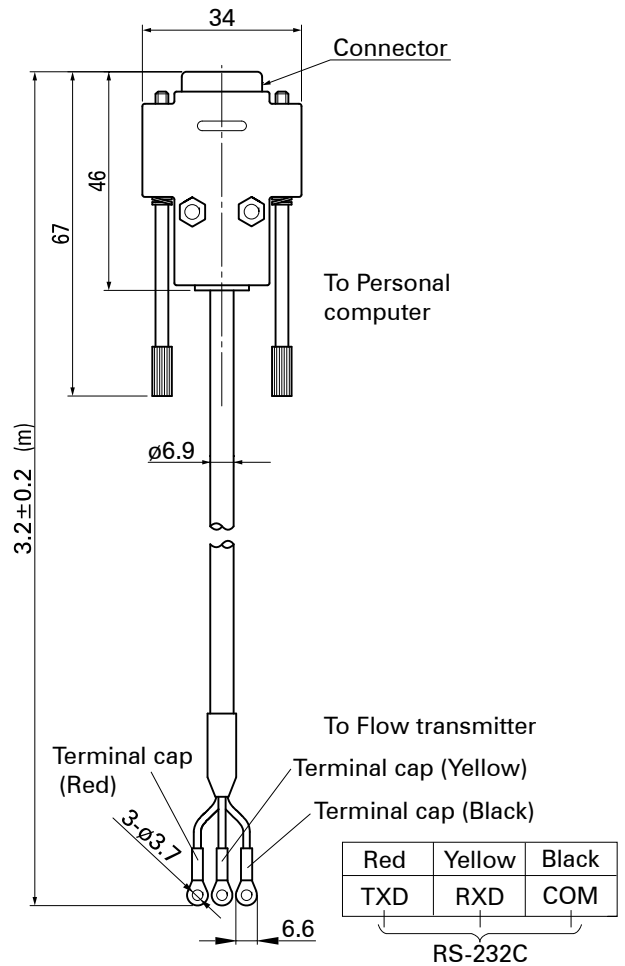

<Parameter specification table>

No.	Setting item	Settable range	Initial value	Settable value	
1	Piping specification	Outer diameter	10.00 to 6200.00mm (0.393 to 244.100 inch)	60.00mm (2.362 inch)	[mm, inch]
2		Pipe material	12 menus Pipe S.V. : 1000 to 3700m/s (3280 to 12140 ft/s)	PVC	Carbon steel, Stainless steel, PVC, Copper, Castiron, Aluminum, FRP, Ductileiron, PEEK, PVDF, Acrylic Others (Sound velocity : [m/s, ft/s])
3		Wall thickness	0.10 to 100.00mm (0.003 to 3.940 inch)	4.00mm (0.157 inch)	[mm, inch]
4		Lining material	8 menus Lining S.V. : 1000 to 3700m/s (3280 to 12140 ft/s)	No lining	No lining, Tar epoxy, Mortar, Rubber, Teflon, Pyrex glass, PVC, Others (Sound velocity : [m/s, ft/s])
5		Lining thickness	0.01 to 100.00mm (0.000 to 3.940 inch)	—	[mm, inch]
6		Kind of Fluid	17 menus Fluid S.V. : 500 to 2500m/s (1641 to 8203 ft/s) Kinematic viscosity : 0.001 to 999.9999 x 10 ⁻⁶ m ² /s (0.0107 to 10763.9088 x 10 ⁻⁶ ft ² /s)	Water	Water, Seawater, DIST. water, Ammonia, Alcohol, Benzene, Bromide, Ethanol, Glycol, Kerosene, Milk, Methanol, Toluol, Lube oil, Fuel oil, Petrol, Others (Sound velocity : [m/s, ft/s]) (Kinematic viscosity [x10 ⁻⁶ m ² /s, ft ² /s])
7	Output setting	Range unit	19 menus	m/s (ft/s)	m/s, L/s, L/min, L/h, L/d, kL/d, ML/d, m ³ /s, m ³ /min, m ³ /h, m ³ /d, km ³ /d, Mm ³ /d, BBL/s, BBL/min, BBL/h, BBL/d, KBBL/d, MBBL/d, (ft/s, ft ³ /s, ft ³ /min, ft ³ /h, ft ³ /d, kft ³ /d, Mft ³ /d, gal/s, gal/min, gal/h, gal/d, kgal/d, Mgal/d, BBL/s, BBL/min, BBL/h, BBL/d, kBBL/d, MBBL/d)
8		Range type	4 menus	Single	Single, Auto 2, Bi-dir, Bi-dir Auto 2
9		Full scale or Full scale 1	In terms of flow velocity 0.00 ... 0.30 to 32.00m/s (0.98 to 104.98 ft/s)	2.00m/s (6.56 ft/s)	[]
10		Full scale 2	In terms of flow velocity 0.00 ... 0.30 to 32.00m/s (0.98 to 104.98 ft/s)	4.00m/s (13.12 ft/s)	[]
11		Range HYS.	0.00 to 20.0%	10.00%	%
12		Output limit LO.	-20 to 0%	-20%	%
13		Output limit HI.	100 to 120%	120%	%
14		Output burnout	5 menus	Hold	Not use, Hold, Upper, Lower, Zero
15		Burnout timer	0 to 900sec	10sec	sec
16		Rate limit	0.00 to 5.00m/s (0.00 to 16.40 ft/s) in terms of flow velocity	0.00m/s (0.00 ft/s)	[]
17	Rate limit timer	0 to 900sec	0sec	sec	
18	Damping	0.0 to 100.0sec	5.0sec	sec	
19	Display setting	1 : Display kind	7 menus	Flowrate (m ³ /s)	Flow velocity, Flowrate, Total forward, Total reverse, F : Total pulse, R : Total pulse, Flow rate (%)
20		2 : Display kind	7 menus	Flow velocity (m/s)	Flow velocity, Flowrate, Total forward, Total reverse, F : Total pulse, R : Total pulse, Flow rate (%)
21	Low flow cut	0.00 to 5.00m/s (0.00 to 16.40 ft/s) in terms of flow velocity	0.01m/s (0.03 ft/s)	[]	

No.	Setting item	Settable range	Initial value	Settable value
22	Total mode	3 menus	Total stop	Total stop, Total run, Total reset
23	Total unit	8 menus	mL	mL, L, m ³ , km ³ , Mm ³ , mBBL, BBL, kBBL, ft ³ , kft ³ , Mft ³ , kgal, gal, mBBL, BBL, kBBL, ACRF
24	Total rate	0.000 to 999999.999	0.000	[]
25	F : Total preset	0.000 to 9999999999.999	0.000	[]
26	F : Total SW	0.000 to 9999999999.999	0.000	[]
27	R : Total preset	0.000 to 9999999999.999	0.000	[]
28	R : Total SW	0.000 to 9999999999.999	0.000	[]
29	Output burnout	2 menus	Hold	Not use, Hold
30	Burnout timer	0 to 900sec	10sec	sec
31	Pulse width 1	3 menus	50ms	50, 100, 200
32	Pulse width 2	9 menus	50ms	0.5, 1.0, 2.0, 5.0, 10.0, 20.0, 50.0, 100.0, 200.0
33	Flow sw high	In terms of flow velocity 0.00 to 32.00m/s (0.00 to 104.98 ft/s)	0.00m/s	[]
34	Flow sw low	In terms of flow velocity 0.00 to 32.00m/s (0.00 to 104.98 ft/s)	4.00m/s	[]
35	Flow sw HYS.	0 to 20%	10%	%
36	Output DO1	15 menus	Not use	Not use, Signal error, F : Total pulse, R : Total pulse, F : Total alarm, R : Total alarm, F : Total overflow, R : Total overflow, Flow SW high, Flow SW Low, Full scale2, AO range over, Pulse range over, R : Flow direction, Device error
37	Mode DO1	2 menus	Normal	Normal, Reverse
38	Output DO2	15 menus	Not use	Not use, Signal error, F : Total pulse, R : Total pulse, F : Total alarm, R : Total alarm, F : Total overflow, R : Total overflow, Flow SW high, Flow SW Low, Full scale2, AO range over, Pulse range over, R : Flow direction, Device error
39	Mode DO2	2 menus	Normal	Normal, Reverse
40	Output DO3	15 menus	Not use	Not use, Signal error, F : Total pulse, R : Total pulse, F : Total alarm, R : Total alarm, F : Total overflow, R : Total overflow, Flow SW high, Flow SW Low, Full scale2, AO range over, Pulse range over, R : Flow direction, Device error
41	Mode DO3	2 menus	Normal	Normal, Reverse

No.	Setting item		Settable range	Initial value	Settable value	
42	System unit		2 menus	Metric	Metric, English	
43	Language		5 menus	English	Japanese, English, German, French, spanish	
44	System	Serial com.	COM. speed	3 menus	38400BPS	9600BPS, 19200BPS, 38400BPS
45			COM. parity	3 menus	None	None, Even, Odd
46			COM. stop bit	2 menus	1 bit	1 bit, 2bits
47			Serial method	2 menus	RS232C	RS232C, RS485
48			Station No.	31 menus	1	1 to 31
49	Measurement mode	Measurement mode	2 menus	1 Path (2 path) Note2	2 Path	
50		AO Definition	3 menus	Line 1 (Average) Note2	Average, Line 1, Line 2	

Note1: When total pulse output has been selected for DO1, DO2 or DO3 specify total pulse value and total pulse width so that conditions 1 and 2 shown below are satisfied.

$$\text{Condition 1 : } \frac{\text{Flow span-1} \cdot [\text{m}^3/\text{s}]}{\text{total pulse value} \cdot [\text{m}^3]} \leq \begin{cases} 1000 & [\text{In the case of DO1 and DO2}] \\ 1 & [\text{In the case of DO3}] \end{cases}$$

$$\text{Condition 2 : } \frac{\text{Flow span-1} \cdot [\text{m}^3/\text{s}]}{\text{total pulse value} \cdot [\text{m}^3]} \leq \frac{1000}{2 \times \text{total pulse width} [\text{ms}]}$$

* In the case of 2 ranges, perform calculations using either flow span-1 or flow span-2, whichever is greater.

Note2: Settable value at the time of shipment.

⚠ Caution on Safety

*Before using this product, be sure to read its instruction manual in advance.



Grobal Sales Section
Instrumentation & Sensors Planning Dept.
 1, Fuji-machi, Hino-city, Tokyo 191-8502, Japan
<http://www.fujielectric.com>
 Phone: +81-42-514-8930 Fax: +81-42-583-8275
<http://www.fujielectric.com/products/instruments/>

Information in this catalog is subject to change without notice.

Printed in Japan